

**High performance electric forklift with enclosed, twin AC motor front wheel drive**

**5 individually adjustable working programs**

**Comfortable workstation with SOLO- or MULTI-PILOT control (optional)**

**Jungheinrich Curve Control for safer driving and cornering**

**Maintenance-free multiple disc brakes**



## **EFG 213–220**

### **Electric three-wheel forklift truck (1300, 1500, 1600, 1800, 2000 kg)**

The use of innovative three-phase AC technology opens up new possibilities and provides numerous advantages for electric forklift trucks:

- Excellent performance values for acceleration, travel and lift speeds allow for maximum productivity
- More work per battery charge as a result of optimum efficiency and more effective energy recovery
- Precise hydrostatic power steering and solid-state electric braking when the accelerator is released

- Maintenance-free brushless enclosed three phase AC motors protected to IP 54. This ensures faster working cycles and significantly longer operation per battery charge. Low day-to-day operating costs, together with reduced maintenance requirements, guarantee outstanding economic efficiency.

Compact design makes the three wheel truck extremely manoeuvrable and allows fast operation in the most confined spaces for example lorries, containers or railway

wagons. The closed design and the front wheel drive ensure a universal suitability and optimal traction on gradients and slippery surfaces.

# EFG 213–220

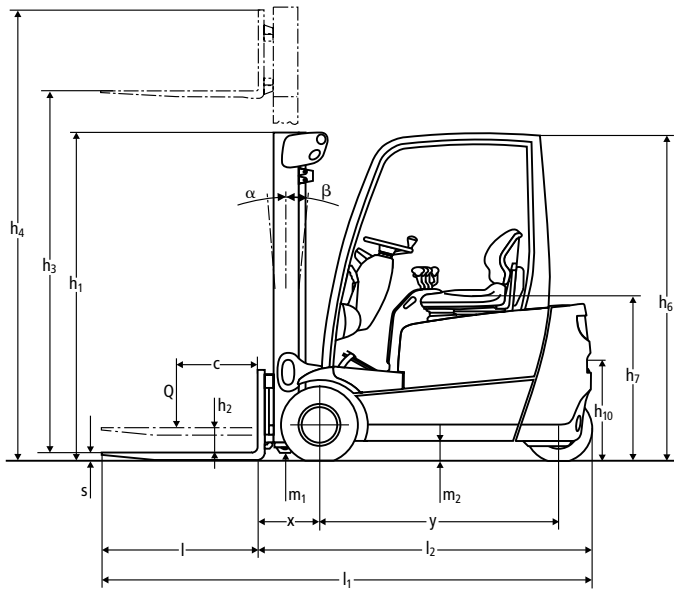

## Capacity

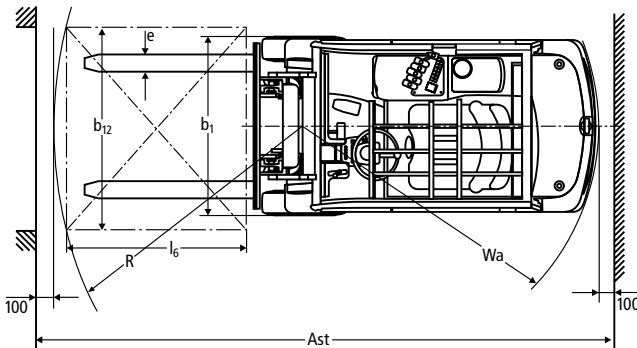
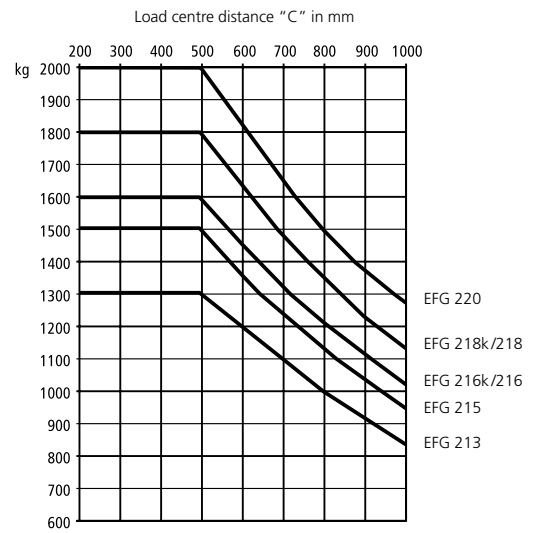

Designation	Lift h <sub>3</sub> mm	Mast Table EFG 213–220			Max. height h <sub>4</sub> mm		Tilt forward / backward α/β (°)	Capacity table (kg) c = 500 mm without sideshift, single solid tyres				
		Free lift h <sub>2</sub> mm		Closed mast height h <sub>1</sub> mm	EFG 213– 216k/216	EFG 218k/ 218–220		EFG 213	EFG 215	EFG 216k/216	EFG 218k/218	EFG 220
		EFG 213– 216k/216	EFG 218k/ 218–220									
Two-stage ZT	2300	150	150	1650	2850	2885	7°/4°	1300	1500	1600	1800	2000
	3000	150	150	2000	3550	3585	7°/7°	1300	1500	1600	1800	2000
	3100	150	150	2050	3650	3685	7°/7°	1300	1500	1600	1800	2000
	3300	150	150	2150	3850	3885	7°/7°	1300	1500	1600	1800	2000
	3600	150	150	2300	4150	4185	7°/7°	1300	1500	1600	1800	2000
	4000	150	150	2500	4550	4585	7°/7°	1300	1500	1600	1800	2000
	4500	150	150	2800	5050	5085	7°/7°	1300	1500	1600	1800	2000
	5000	150	150	3050	5550	5585	7°/5°	1200	1400	1500	1700	1850
5500*	150	150	3400	6050	6085	7°/5°	1100	–	1400	1550	1650	
Two-stage ZZ	2300	1055	990	1605	2850	2915	7°/4°	1300	1500	1600	1800	2000
	3000	1405	1340	1955	3550	3615	7°/7°	1300	1500	1600	1800	2000
	3100	1455	1390	2005	3650	3715	7°/7°	1300	1500	1600	1800	2000
	3300	1555	1490	2105	3850	3915	7°/7°	1300	1500	1600	1800	2000
	3600	1705	1640	2255	4150	4215	7°/7°	1300	1500	1600	1800	2000
4000	1905	1840	2455	4550	4615	7°/7°	1300	1500	1600	1800	2000	
Three-stage DZ	4350	1405	1340	1955	4900	4965	7°/6°	1300	1500	1600	1800	2000
	4500	1455	1390	2005	5050	5115	7°/6°	1300	1450	1600	1800	2000
	4800	1555	1490	2105	5350	5415	7°/6°	1250	1400	1550	1700	1900
	5000	1630	1565	2180	5550	5615	7°/6°	1200	1350	1500	1650	1800
	5500	1805	1740	2355	6050	6115	7°/5°	1050	1250	1350	1500	1600
	6000*	2005	1940	2555	6550	6615	7°/5°	900	–	1150	1300	1400
	6500*1)	2255	2190	2805	7050	7115	7°/5°	750	–	950	1100	1150

\* Mast not available for EFG 215  
1) EFG 216 width of chassis is 1088 mm

# Technical Data in line with VDI 2198 as at: 09/2003

		Jungheinrich		Jungheinrich		Jungheinrich		Jungheinrich					
		EFG 213	EFG 215	EFG 216k	EFG 216	EFG 218k	EFG 218	EFG 220					
Identification	1.1	Manufacturer (abbreviation)		Jungheinrich		Jungheinrich		Jungheinrich	1.1				
	1.2	Manufacturer's type designation		EFG 213	EFG 215	EFG 216k	EFG 216	EFG 218k	EFG 218	EFG 220	1.2		
	1.3	Drive: electric (battery or mains), diesel, petrol, fuel gas, manual		electric		electric		electric		electric	1.3		
	1.4	Type of operation: hand, pedestrian, standing, seated, order-picker		seated		seated		seated		seated	1.4		
	1.5	Load capacity/rated load	Q (t)	1.3	1.5	1.6		1.8		2.0	1.5		
	1.6	Load centre distance	c (mm)	500		500		500		500	1.6		
	1.8	Load distance, centre of drive axle to fork	x (mm)	347 <sup>1)</sup>		352 <sup>2)</sup>		352 <sup>2)</sup>		352 <sup>2)</sup>	1.8		
	1.9	Wheelbase	y (mm)	1249		1357	1465	1357	1465	1465	1.9		
	Weights	2.1	Service weight	kg	2800	2990	2990	3185	3100	3170	3205	2.1	
2.2		Axle loading, laden front/rear	kg	3490/610	3930/560	4015/575	4030/755	4415/485	4375/595	4665/540	2.2		
2.3		Axle loading, unladen front/rear	kg	1310/1490	1415/1575	1410/1580	1500/1685	1485/1615	1530/1640	1500/1705	2.3		
Wheels, Chassis	3.1	Tyres: solid rubber, superelastic, pneumatic, polyurethane		SE(L)/SE(L)		SE(L)/SE(L)		SE/SE		SE/SE	3.1		
	3.2	Tyre size, front		18x7-8		18x7-8		200/50-10		200/50-10	3.2		
	3.3	Tyre size, rear		140/55-9		140/55-9		140/55-9		140/55-9	3.3		
	3.5	Wheels, number front rear (x = driven wheels)		2x2		2x2		2x2		2x2	3.5		
	3.6	Track width, front	b <sub>10</sub> (mm)	904		904		914		914	3.6		
	3.7	Track width, rear	b <sub>11</sub> (mm)	176		176		176		176	3.7		
	Basic Dimensions	4.1	Mast/fork carriage tilt forward/backward		α/β (°)		7/7		7/7		7/7	4.1	
4.2		Lowered mast height		h <sub>1</sub> (mm)		2000		2000		2000	4.2		
4.3		Free lift		h <sub>2</sub> (mm)		150		150		150	4.3		
4.4		Lift height		h <sub>3</sub> (mm)		3000		3000		3000	4.4		
4.5		Extended mast height		h <sub>4</sub> (mm)		3550		3550		3585	4.5		
4.7		Overhead load guard (cab) height		h <sub>6</sub> (mm)		1960		1960		1960	4.7		
4.8		Seat height/standing height		h <sub>7</sub> (mm)		890		890		890	4.8		
4.12		Coupling height		h <sub>10</sub> (mm)		560		560		560	4.12		
4.19		Overall length		l <sub>1</sub> (mm)		2936	3049	3157	3049	3157	3157	4.19	
4.20		Length to face of forks		l <sub>2</sub> (mm)		1786	1899	2007	1899	2007	2007	4.20	
4.21		Overall width		b <sub>1</sub> (mm)		1060		1060		1120	1120	4.21	
4.22		Fork dimensions		s/e/l (mm)		35x100x1150		40x100x1150		40x100x1150	40x100x1150	4.22	
4.23		Fork carriage ISO 2328, class/type A, B		2A		2A		2A		2A	2A	4.23	
4.24		Fork-carriage width		b <sub>3</sub> (mm)		980		980		980	980	4.24	
4.31		Ground clearance, laden, under mast		m <sub>1</sub> (mm)		90		90		90	90	4.31	
4.32		Ground clearance, centre of wheelbase		m <sub>2</sub> (mm)		100		100		100	100	4.32	
4.33		Aisle width for pallets 1000x1200 crossways		Ast (mm)		3115	3224	3334	3224	3334	3334	4.33	
4.34		Aisle width for pallets 800x1200 lengthways		Ast (mm)		3238	3348	3458	3348	3458	3458	4.34	
4.35		Turning radius		Wa (mm)		1440		1545		1655	1655	4.35	
4.36	Smallest pivot point distance		b <sub>13</sub> (mm)		0		0		0	0	4.36		
Performance Data	5.1	Travel speed, laden/unladen		km/h		16.0		16.0		16.0	5.1		
	5.2	Lift speed, laden/unladen		m/s		0.48/0.60	0.46/0.60	0.46/0.60	0.38/0.50	0.38/0.50	5.2		
	5.3	Lowering speed, laden/unladen		m/s		0.55		0.55		0.55	5.3		
	5.5	Drawbar pull, laden/unladen S <sub>2</sub> 60 min		N		2300/2500	2200/2450	2150/2450	2100/2450	2000/2300	1900/2300	5.5	
	5.6	Max. drawbar pull, laden/unladen S <sub>2</sub> 5 min		N		12700/12700		12700/12700		12400/12200	12300/12000	5.6	
	5.7	Gradient performance, laden/unladen S <sub>2</sub> 30 min		%		7.6/12.5	7.3/12.3	7.3/12.3	7.0/11.5	6.2/10.7	5.9/10.5	5.7/10.4	5.7
	5.8	Max. gradient performance, laden/unladen S <sub>2</sub> 5 min		%		28.0/35.0	27.0/35.0	27.0/35.0	26.0/35.0	25.0/35.0	24.0/35.0	5.8	
	5.9	Acceleration time, laden/unladen 10 m		s		3.6/3.2	3.8/3.4	3.8/3.4	3.9/3.5	4.0/3.5	5.9		
	5.10	Service brake				hydr./electr.		hydr./electr.		hydr./electr.	hydr./electr.	5.10	
	E-Motor	6.1	Drive motor rating S <sub>2</sub> 60 min		kW		2x4.0=8.0		2x4.0=8.0		2x4.0=8.0	6.1	
6.2		Lift motor rating at S <sub>3</sub> 15 %		kW		10.0		10.0		10.0	6.2		
6.3		Battery acc. to DIN 43531 / 35/36 A, B, C, no				DIN 43531 A		DIN 43531 A	DIN 43531 A	DIN 43531 A	DIN 43531 A	6.3	
6.4		Battery voltage, nominal capacity K <sub>s</sub>		V/Ah		48/460		48/575	48/690	48/575	48/690	48/690	6.4
6.5		Battery weight		kg		715		855	1025	855	1025	1025	6.5
6.6		Battery dimensions l/w/h		cm		827/519/627		827/735/627	827/735/627	827/735/627	827/735/627	827/735/627	6.6
Other Details	8.1	Type of drive control				Impulse/AC		Impulse/AC		Impulse/AC	Impulse/AC	8.1	
	8.2	Operating pressure for attachments		bar		ca. 200		ca. 200		ca. 200	ca. 200	8.2	
	8.3	Oil volume for attachments		l/min		25		25		25	25	8.3	
	8.4	Sound level at driver's ear according to DIN 12 053 dB (A)				66		66		66	66	8.4	
	8.5	Tow coupling, type DIN				15170/type H		15170/type H		15170/type H	15170/type H	8.5	

1) with DZ mast +25 mm; with integrated sideshift x = 370 mm (with DZ mast +25 mm); with hook-on sideshift x = 405.5 mm (with DZ mast +25 mm)  
 2) with DZ mast +25 mm; with integrated sideshift x = 375 mm (with DZ mast +25 mm); with hook-on sideshift x = 410.5 mm (with DZ mast +25 mm)

# Make use of the advantages

## Superior Operator Comfort

Functionality and Ergonomics of the driver compartment guarantees relaxed and fatigue-free work over long shifts:

- Low access step. Large, level foot well with automotive pedal lay-out.
- Adjustable steering column and hydraulic comfort seat for optimum seating position
- Floating cab module cushions road shocks and vibrations
- Clear view: mast and fork carriage allow for excellent visibility to load and road
- Hydraulic power steering is precise and low effort, without kick-back



SOLO-PILOT

- Comfort Display provides up-to-date information on vital vehicle conditions at a glance
- Comfortable, fatigue-free operation of direction and hydraulics by SOLO-PILOT control (separate levers) or MULTI-PILOT control (optional), all functions controlled by one lever.
- Convenient storage for documents and the operators belongings.

## Safe, wear-free braking

Three distinct systems ensure safe, precise and largely wear-free braking:

- Regenerative electric braking in reversing mode and regular brake pedal use



MULTI-PILOT

- Multiple oil disc brakes act as a safety back-up. Wear-free and fully enclosed.
- Parking brake uses the service brake system through a separate electric actuation system. Operation warning light in the drivers console.

## Maintenance free electric motors

Proven AC technology: 2 drive motors, hydraulic pump motor, steering motor. High performance, low energy consumption, less maintenance:

- High torque for rapid work cycles
- Up to 15% higher energy efficiency than shunt motors
- No brushes, no collector – no maintenance expense
- Fully enclosed and protected to IP 54. Long life, even under dusty and damp conditions
- 2 years warranty on all motors

## Active safety

Excellent drive dynamics and performance also demand a high degree of safety:

- Curve Control automatically reduces travel speed when cornering
- Rollback protection ensures controlled operation on ramps and slopes
- Very low centre of gravity improves stability and residual capacity

- Twin wheel steering axle with low profile tyres ensures stable handling and smooth travel
- Electronic and hydraulic overload protection guard
- Traction Control ensures optimum torque in curves
- Emergency cut off switch quickly accessible
- Reliable data transfer between electronic components through CAN bus technology

## Intelligent electronics

Board Control electronic system permanently controls and monitors all truck functions.

- Smooth driving, dynamic reversing and precise load positioning with a minimum of energy



BoardControl

- 5 application programs can be individually adapted to ensure optimal performance in any application.
- Diagnostic system monitors all components and provides service data memory for rapid and cost-effective maintenance
- Comfort-Display with digital service hour meter (actual or cyclic duration factor), battery discharge indicator plus lift cut-out, clock, error code and warning displays
- Electronic steer wheel position indicator

## Jungheinrich Aktiengesellschaft

Friedrich-Ebert-Damm 129  
22047 Hamburg  
Telefon 0180 5235468\*  
Telefax 0180 5235469\*

\*Bundesweit nur € 0,12 pro Minute

info@jungheinrich.de  
www.jungheinrich.de

ISO-9001, ISO-14001-  
Certification of Quality and  
Environment Management.



Jungheinrich trucks  
conform to the European  
Safety Requirements.



**JUNGHEINRICH**  
Well worthwhile